



Vito & eVito Technical Data.

Model Year 2025.

Effective July 2025.

Mercedes-Benz



Weights and Payload

	National Type	Gross Vehicle Mass (Kg)	Unladen Mass (Kg)	Payload (Kg)	Gross Combination Mass (Kg)	Towing Capacity - Braked (Kg)	Towing Capacity - Unbraked (Kg)	Permissible max. front axle load (Kg)	Permissible max. rear axle load (Kg)
Panel Van									
116 LWB Van RWD	44760523-N4Y	3000	2044	957	5500	2500	750	1550	1750
112 LWB Electric Van FWD	44760523-NGA	3200	2374	826	NA	NA	NA	1700	1750
Crew Cab									
116 LWB Crew Cab RWD	44770523-N4R	3200	2198	1002	5550	2500	750	1550	1650
Vito Tourer									
Vito Tourer 116 MWB RWD	44770323-N4C	3100	2375	725	5600	2500	750	1550	1750
eVito Tourer 129 MWB FWD	44770323-NEF	3500	2877	623	NA	NA	NA	1550	1750

Applicable Models only.

When ordered with the Weight variant 3.2t GVM XA5:
 Permissible max. front axle load (Kg): 1550
 Permissible max. rear axle load (Kg): 1750

1. Gross Combination Mass (GCM) is the total permissible combined weight of the vehicle including occupants, fuel, cargo plus trailer being towed if any.
2. Gross Vehicle Mass (GVM) is the total permissible weight of the vehicle including occupants, fuel and cargo.
3. Payload = GVM - Unladen mass
4. Unladen mass = vehicle with all standard equipment, 100% fuel and no occupants

Weights are intended as a guide only. For accuracy, the actual vehicle should always be weighed to determine the exact weight for the specifications ordered. Weight tolerance of +/- 5% in production, and additional weight of optional equipment must be taken in consideration.

Fuel Consumption

Model	National Type	CO2 urban [g/km]	CO2 extra-urban [g/km]	CO2 combined [g/km]	FC urban [l/100 km]	FC extra-urban [l/100 km]	FC combined [l/100 km]
Panel Van							
116 LWB Van RWD	44760523-N4Y	196	155	171	7.5	5.9	6.5
Crew Cab							
116 LWB Crew Cab RWD	44770523-N4R	199	158	174	7.6	6.0	6.6
Vito Tourer							
Vito Tourer 116 MWB RWD	44770323-N4C	201	160	176	7.6	6.1	6.7

The declared fuel consumption figures are determined by testing under standardised laboratory conditions in accordance with ADR 81/02. The fuel consumption figures stated are for the purposes of comparison amongst vehicles tested under the same technical procedures only. Real world energy consumption figures may vary and are influenced by many factors such as, individual driving style, load, traffic, ambient temperature and vehicle condition.

Dimensions Panel Van (MWB)

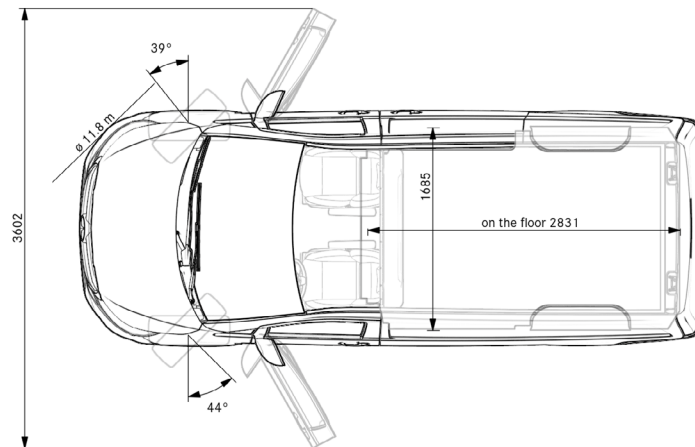
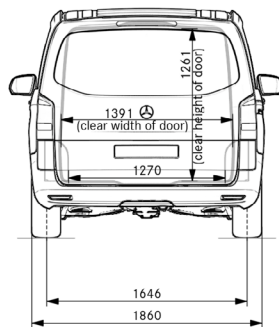
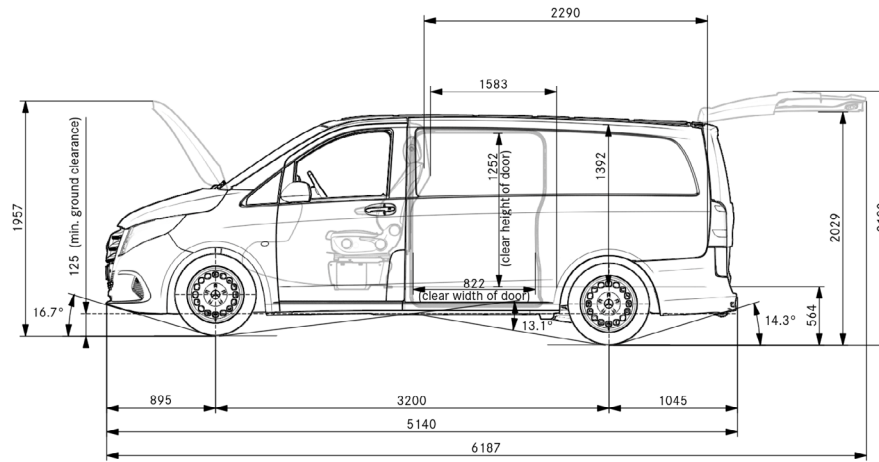
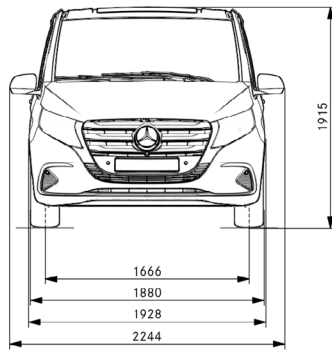

Turning circle (curb to curb): 11.1m

Dimensions Panel Van (LWB)

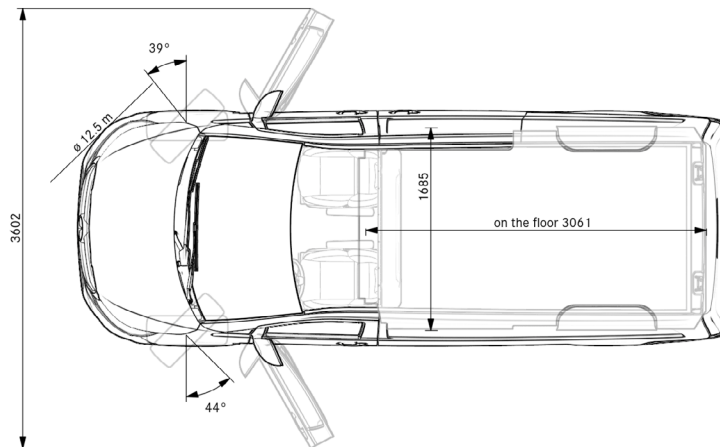
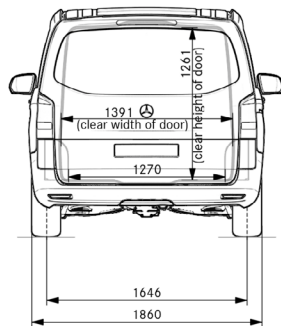
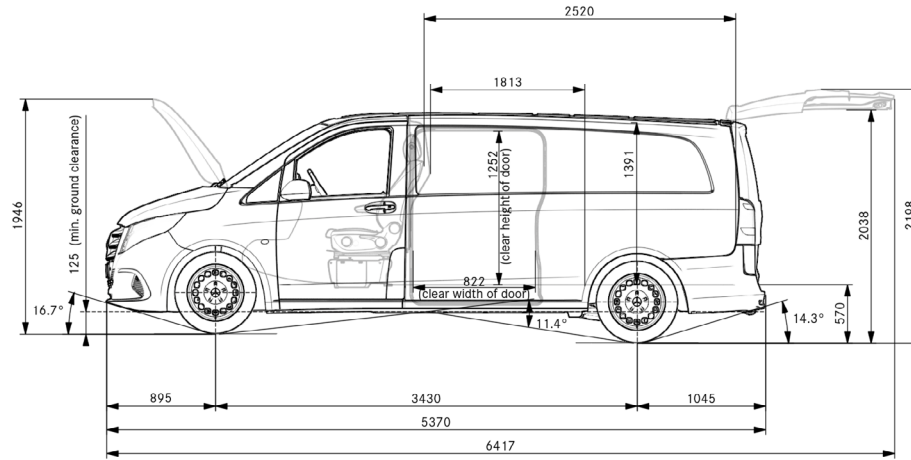
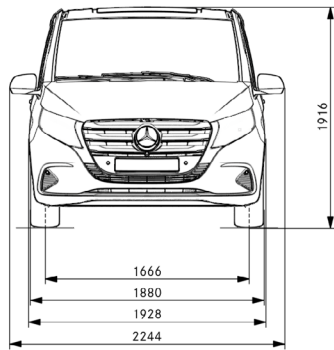

Turning circle (curb to curb): 11.1m

Dimensions Crew Cab (LWB)

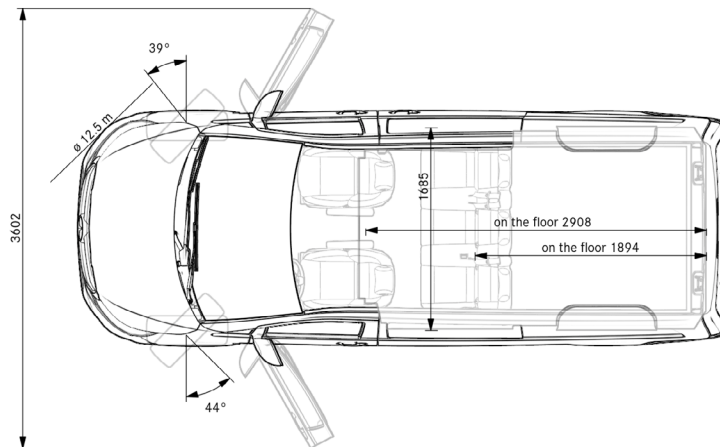
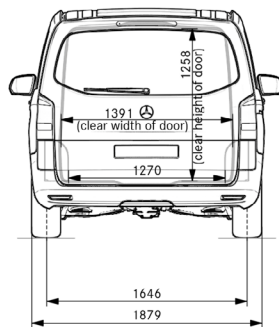
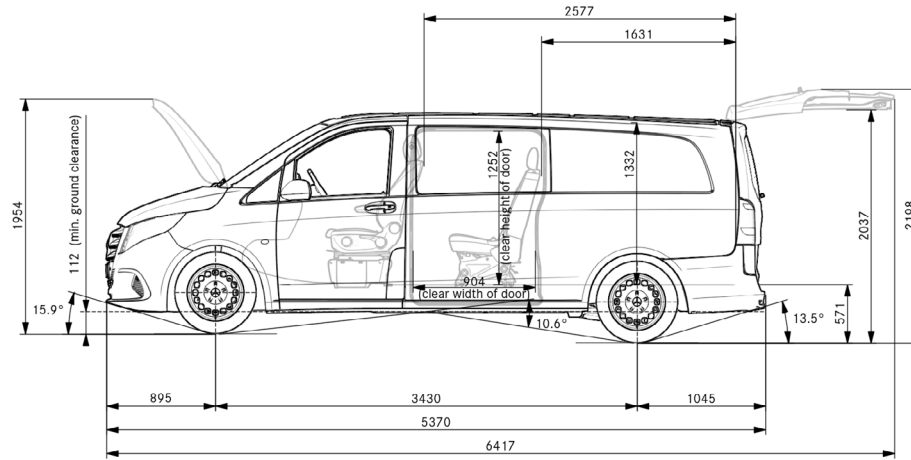
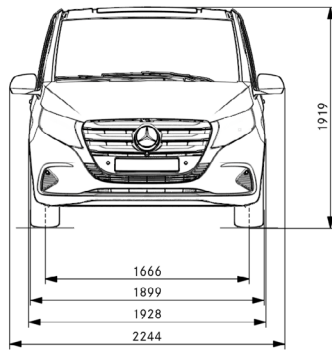

Turning circle (curb to curb): 11.1m

Dimensions Vito Tourer (MWB)

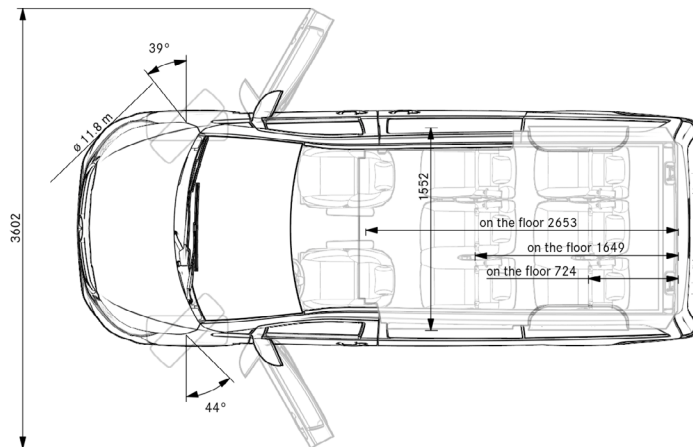
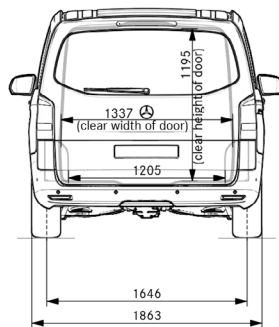
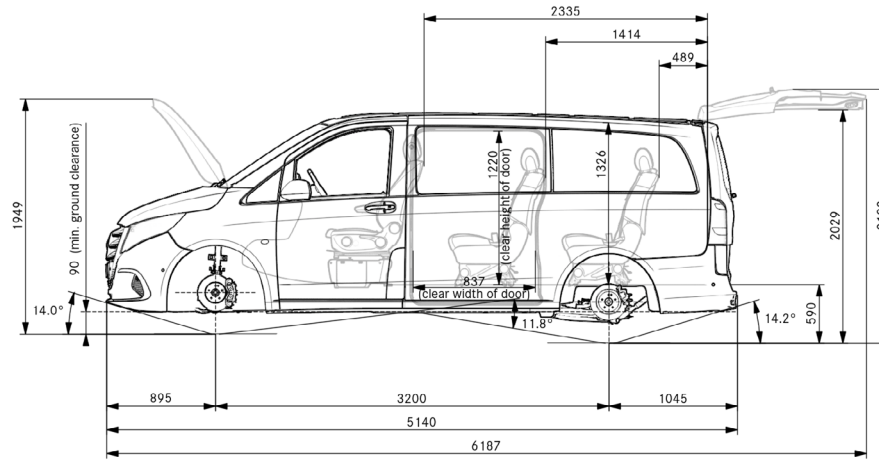
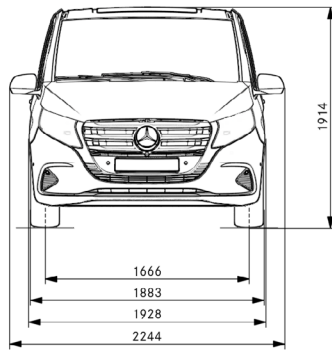

Turning circle (curb to curb): 11.1m

Dimensions eVito Tourer (MWB)

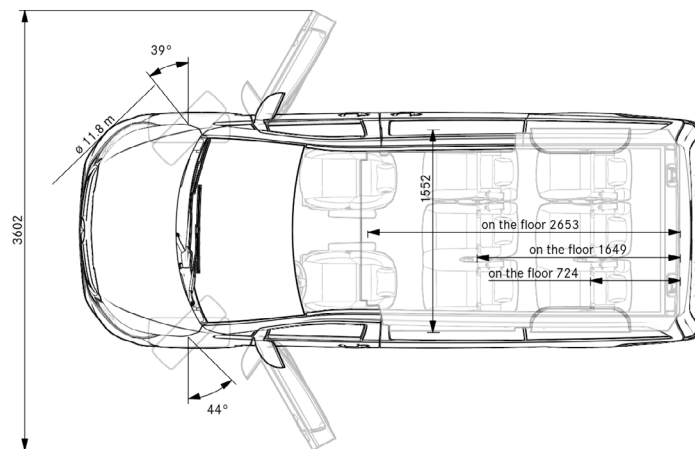
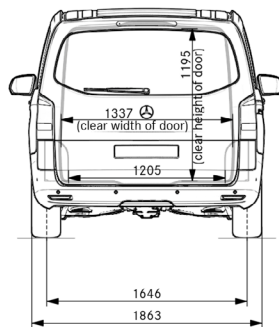
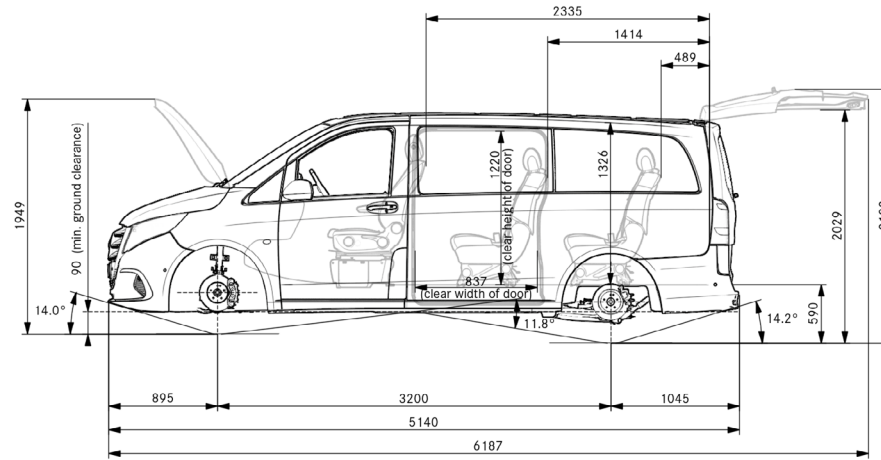
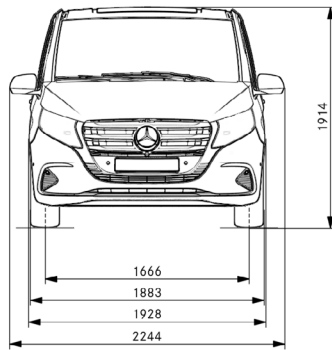

Turning circle (curb to curb): 11.1m